

One side fully coated multilayer SBS board with light coated reverse

Ensocoat is a luxurious, coated SBS (solid bleached sulphate) board with a three-layer fibre construction of chemical pulp. It is double-coated on the top side, with one layer of coating on the reverse side.

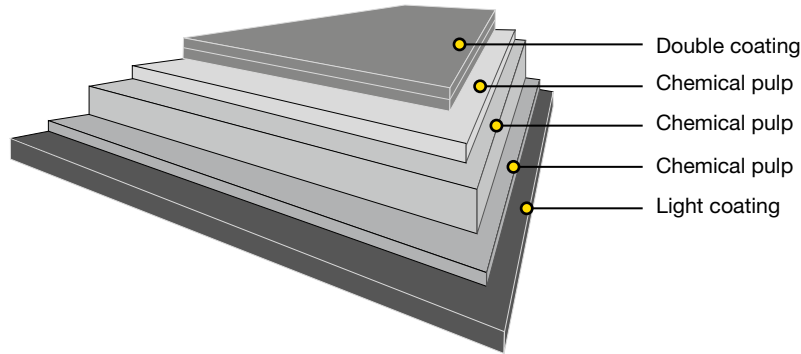

Issued: 11.2017
Cancels: 01.2017

Technical specification

Property / Unit	Tolerance												Standards
Grammage, g/m ²	±4%	180*	190	210	220**	230	250	275	300	330	350	380	ISO 536
Thickness, µm	±4%	195	200	230	265	270	300	330	365	415	445	485	ISO 534
Bending resistance L&W 15° MD, mN	-15%	60	75	105	120	160	210	270	375	500	580	740	ISO 2493-1
Bending resistance L&W 15° CD, mN	-15%	26	35	50	60	75	100	130	180	240	270	350	
Bending moment Taber 15° MD, mNm	-15%	3.0	3.6	5.1	6.0	7.7	10.1	13.0	18.1	24.2	28.0	35.7	
Bending moment Taber 15° CD, mNm	-15%	1.5	1.7	2.4	3.0	3.6	4.8	6.3	8.7	11.6	13.0	16.9	
Bending stiffness DIN 5° MD	-15%	5.5	6.4	8.9	11.5	13.6	17.9	23.0	31.9	42.5	49.3	62.9	
Bending stiffness DIN 5° CD	-15%	2.1	3.0	4.3	5.0	6.4	8.5	11.1	15.3	20.4	23.0	29.8	
Moisture, %	±1, ±1.5 ***	6.5	6.5	6.5	6.5	6.5	6.5	6.5	6.5	6.0	6.0	6.0	ISO 287
ISO Brightness C/2°, %, Top		95	95	95	95	95	95	95	95	95	95	95	ISO 2470-1
ISO Brightness C/2°, %, Reverse			93	93	93	93	93	93	93	93	93	93	
CIE Whiteness D65/10°, Top		135	135	135	135	135	135	135	135	135	135	135	ISO 11475
CIE Whiteness D65/10°, Reverse			130	130	130	130	130	130	130	130	130	130	
L* D65/10°, Top		96.5	96.5	96.5	96.5	96.5	96.5	96.5	96.5	96.5	96.5	96.5	ISO 5631-2
a* D65/10°, Top		2.5	2.5	2.5	2.5	2.5	2.5	2.5	2.5	2.5	2.5	2.5	
b* D65/10°, Top		-10.5	-10.5	-10.5	-10.5	-10.5	-10.5	-10.5	-10.5	-10.5	-10.5	-10.5	
Surface Smoothness PPS 10, µm, Top	max 1.4	1.0	0.9	0.9	0.9	0.9	0.9	0.9	0.9	0.9	0.9	0.9	ISO 8791-4
Surface Smoothness PPS 10, µm, Reverse			<4.0	<4.0	<4.0	<4.0	<4.0	<4.0	<5.0	<5.0	<5.0	<5.0	
Surface Smoothness Bendtsen, ml/min, Top		20	20	20	20	20	20	20	20	20	20	20	ISO 8791-2
Surface Smoothness Bendtsen, ml/min, Reverse			<100	<100	<200	<200	<200	<200	<200	<300	<300	<400	
Scott Bond, J/m ²	min 140	220	220	220	220	220	220	220	220	220	220	220	TAPPI 569
Gloss 75°, %, Top		48	48	48	48	48	48	48	48	48	48	48	ISO 8254-1
Robinson chocolate test		<1 for one year storage in reels/pallets											EN 1230-2

*) Uncoated on reverse. Limited availability

***) Limited availability

***) For 330 – 380 g/m²

All properties according to Imatra Mill measurements from board machine production.

Laboratory test climate 23°C/50% RH (According to ISO 187).

Tolerances based upon 95% confidence limits, apply to delivered reel/pallet average.

Bending moment Taber 15° and Bending resistance L&W 15° are binding, Bending stiffness DIN 5° are indicative.

Bending moment Taber 15° calculated from Bending resistance L&W 15°.

One side fully coated multilayer SBS board with light coated reverse

Certificates

Quality management ISO 9001
 Environmental management ISO 14001
 Product safety ISO 22000
 Health and safety OHSAS 18001
 Energy management ISO 50001
 EU Ecolabel registration SE/011/006, the ecological criteria for
 Copying and Graphic Paper 2011/333/EY, L149/12, 8.6.2011



FSC and PEFC certified board available upon request.

The EU Ecolabel confirms that the board fulfils the European Commission's ecological criteria for copying and graphic paper and is therefore only available for graphical end uses.

EU Ecolabel available upon request on graphical end uses.

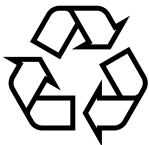

Paperboard is recyclable

Key characteristics and main enduses

Ensocoat is Stora Enso's flagship board, crafted to meet the demands of the graphical industry and luxury packaging. Its surface smoothness, printing performance, brightness, whiteness, UV-light resistance and reverse-side print result have been optimized to impress even in the most demanding applications. Produced from responsibly sourced, certified raw materials, it serves as the industry standard for high performance and sustainability. Ensocoat is used for greeting cards, book covers, brochures, folders, calendars, stationery products and displays. In packaging, it is ideal for cosmetics, perfumes, premium chocolate and laminated boxes for champagne and fine spirits. Thanks to the three-layer fibre construction, Ensocoat has outstanding strength, folding, embossing and converting properties.

Printing and finishing techniques

The product can be used with different printing techniques such as offset, flexo and digital printing. In digital printing, the product is suitable for several different sheet- or web-fed presses. Dry or liquid toner technology can be used, although in some cases, pretreatment of the substrate might be required. The latest certification status can be verified on the press manufacturer's website or with local Stora Enso representatives. It is important to check the limitations of the equipment, particularly because of the exceptional difference in the thickness and stiffness of board compared with paper in the same grammages. When running thicker substrates, the press manufacturer's recommendations should be referred to for optimal grain direction. Essentially all of the same finishing processes apply to both digitally printed and offset printed work. Since a wide variety of digital printing equipment is available in the market, it is important that a new commercial print job is always preceded by a trial run, including all required printing and converting process phases.

The product works very well with different finishing techniques, such as embossing, hot foil stamping and others. It is suitable for laser coding. Certificates according to PTS-DF 105/2013 and PTS-DF 103/2011 are available upon request.

Storage recommendations

For optimal printing results, the moisture proof wrapping should not be removed until the board has reached the temperature of the press room.

Pallet/Reel Weight (kg)	Difference in temperature between board and press room (press room temp. approx. 20°C)		
	10°C	20°C	30°C
400 kg	2 days	2 days	3 days
800 kg	2 days	3 days	4 days
1200 kg	2 days	4 days	5 days

The product properties, according to the specifications, are guaranteed for 12 months after the production date. In order to ensure product safety, the product must be well wrapped and stored indoors, sheltered from rain and snow. The recommended storage conditions are 50-55% relative humidity and 20-23°C.

